



**WIRE-IN HARNESS
FOR PD16**

QUICK START GUIDE

HT-188000



Congratulations on your purchase of the Haltech Wire-In Harness for your PD16 power distribution module. Designed to integrate seamlessly into your existing Haltech Elite or Nexus engine management system, the Nexus PD16 ensures safe, dependable power delivery to your vehicle.

Haltech's PD16 Wire-In Harness simplifies the job of wiring your PD16 into a new or existing Haltech system.

The harness includes a pre-terminated Superseal 34-pin, DTP4 and DTM4 connectors at one end and unterminated, wires at the other. Unterminated wires are organised into groups and clearly labeled.



This harness has been specifically designed for the Haltech PD16 power distribution module. Installation notes, wiring options and a full wiring diagram are included with your PD16 or can be downloaded from our website: www.haltech.com

For more in-depth product overviews, step-by-step set up guides, software walk-throughs and tech tips go to the Haltech YouTube channel.

SCAN ME →



PD16 Optional Accessories (sold separately)

- PD16 Tube Mount Kit 1.25". HT-039080
- PD16 Tube Mount Kitt 1.625". HT-039082
- Plug and Pins Set, 34-Pin. HT-030009
- Plug and Pins Set, DTP06-4s. HT-031201
- Replacement Surlock Connector. HT-030032
- Manual Cable Lug Crimping Tool. HT-070305
- Hydraulic Cable Lug Crimping Tool. HT-070306

Half Bridge Outputs (HBO)

Half Bridge Outputs are push-pull, pulse width modulated (PWM) outputs.

If not being used as push-pull drivers, Half Bridge Outputs can be used as generic high/low PWM outputs capable of sinking 8A to ground and driving 8A to 12V up to 2.2kHz.

HBOs can be used to control any push-pull type device when used as generic high/low switched or PWM outputs.

Half Bridge Outputs can be used as generic low-side DPOs or to control devices such as high-side driven solenoids, high side switched automatic transmission solenoids, etc.

Specs:

- Overcurrent and Overtemperature Protection
- 0 to 27V voltage feedback
- High side current feedback
- Capable of 0-100% duty cycle
- 2.2kHz switching speed

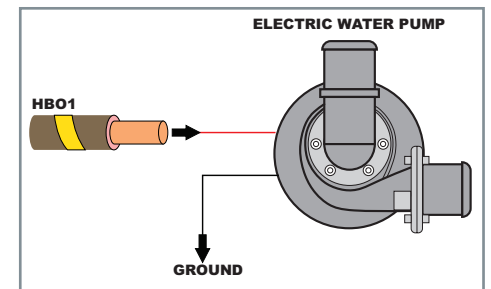
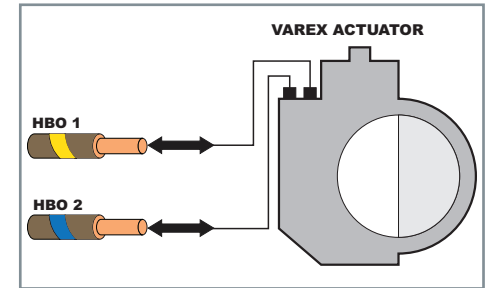

Synchronised Pulsed Inputs (SPI)

SPIs are capable of measuring the position, duty cycle, frequency or state of a signal, as well as analog voltage inputs.

These inputs are suitable for sensors such as fuel composition sensors, road speed sensors and GPS Speed inputs.

SPIs are compatible with digital (hall effect or optical) and retractor (analog) based sensors, have

a maximum input voltage rating of 30V and can measure up to 15KHz maximum frequency.

Specs:

- -0.5 to 12V digital input
- 0 to 5V analog input
- Selectable 1k pull-up to 5V
- -15 to 30V indefinite withstand
- 15.9kHz signal frequency max

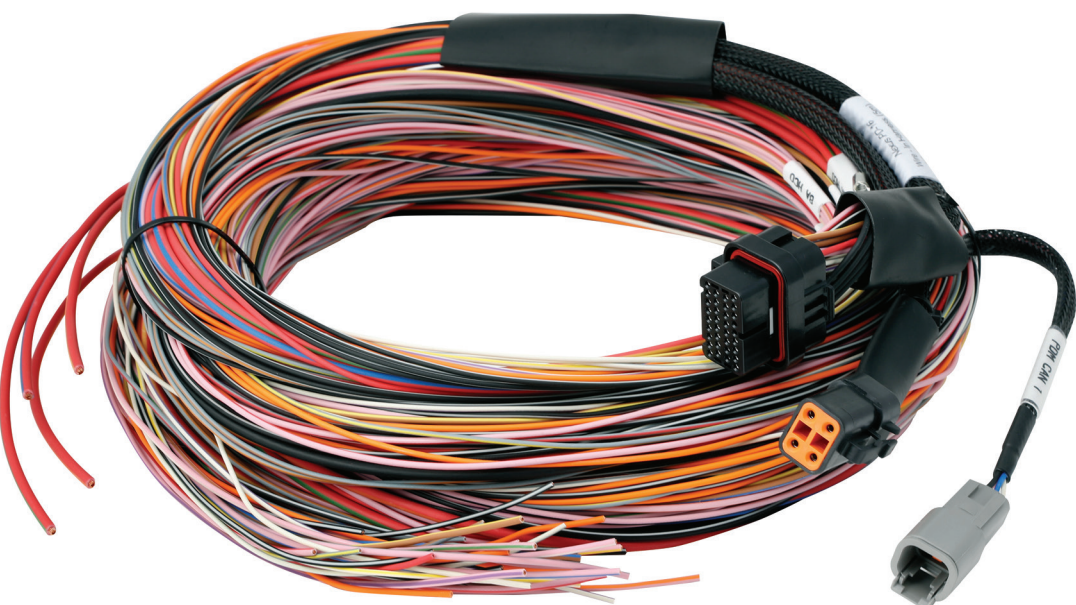
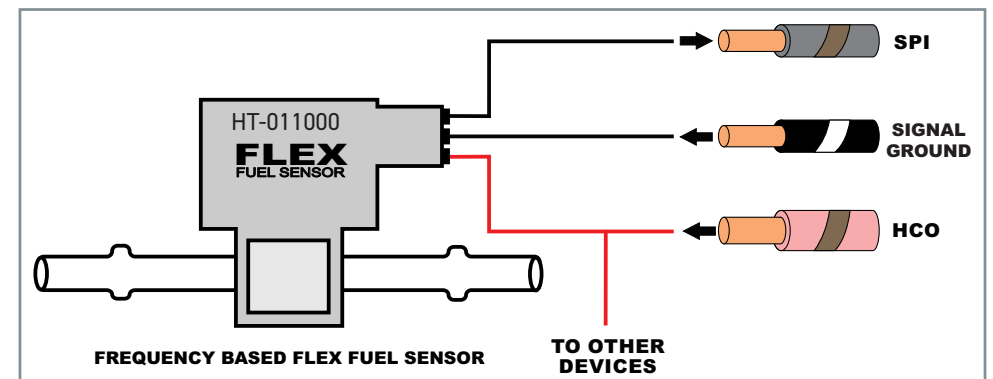

8A High Current Outputs (8A HCO)

The Nexus PD16 features 10 high side outputs capable of driving 8A to 12V. Each output has a software programmable fuse current.

Once the electronic fuse blows the output turns off for a software programmable delay duration, before reactivating the output.

Use the NSP software to define the maximum number of retries before the output is deactivated until the next power cycle. The PD16 LEDs display the output state. 8A HCOs are PWM capable and can be used to power CAN devices or solenoids as well as transmission shift solenoids, water pumps, etc.

Specs:

- Automatic overcurrent protection
- Flyback protected
- 0 to 30V voltage feedback
- High side current feedback
- 100Hz max switching speed
- Capable of 0-100% duty cycle

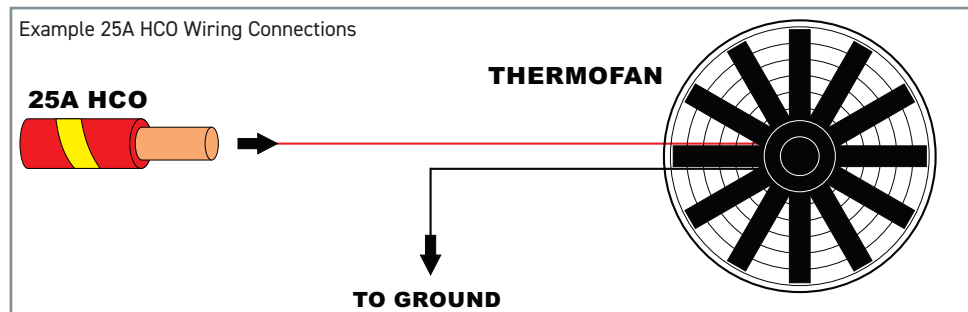
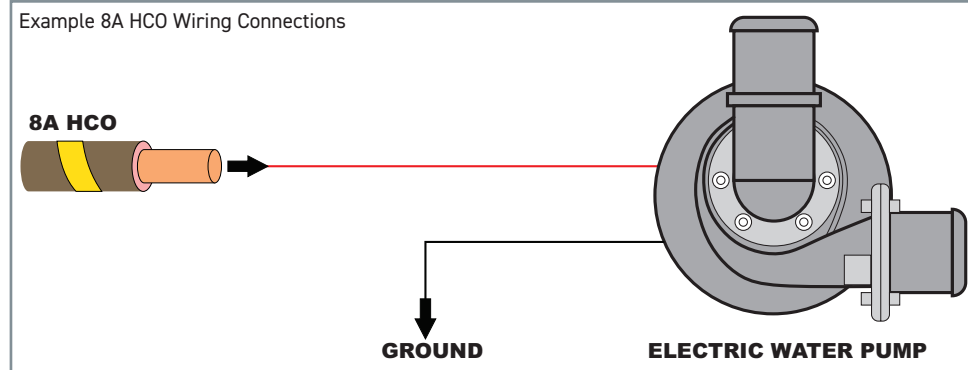

25A High Current Outputs

The four high/low outputs on the Nexus PD16 are capable of driving 25A to 12V. Each output has a programmable fuse current, slow-start current and duration.

Once the electronic fuse blows the output turns off for a pre-programmed delay duration before reactivating the output. The PD16 LEDs display the output state.

25A HCOs are PWM capable and can be used for ignition power and injector power as well as to PWM thermofans and fuel pumps etc.

Specs:

- Automatic overcurrent protection
- Flyback protected
- 0 to 30V voltage feedback
- High side current feedback
- 1kHz max switching speed
- Capable of 0-100% duty cycle

Analog Voltage Inputs (AVI)

Analog Voltage Inputs accept variable voltage signals from 0V to +5V such as signals from pressure, temperature and fuel level sensors.

These inputs can also accept switched inputs that change between two different voltage levels.

The On Voltage and Off Voltage define what the thresholds are between the on and off states. The voltage can be viewed as a channel in NSP to determine the thresholds for a switched input.

AVIs have a software selectable 1K pull-up resistor to 5V, which can be enabled or disabled within the

Setup page. Pull-up resistors are generally enabled for temperature related sensors and switched to ground inputs.

Specs:

- 0 to 5V
- 1000 samples per second
- Selectable 1k pull-up to 5V
- -10 to 30V indefinite withstand
- 1.5kHz signal frequency max
- AVI-1 has a switchable 240Ω pull up that allows direct connection with fuel level sender input.

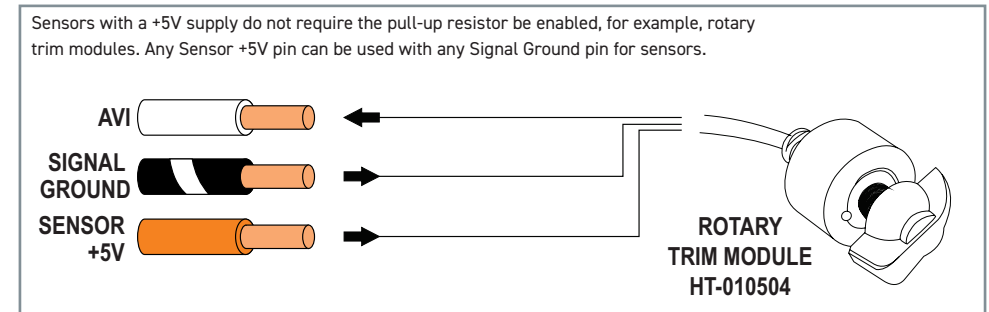
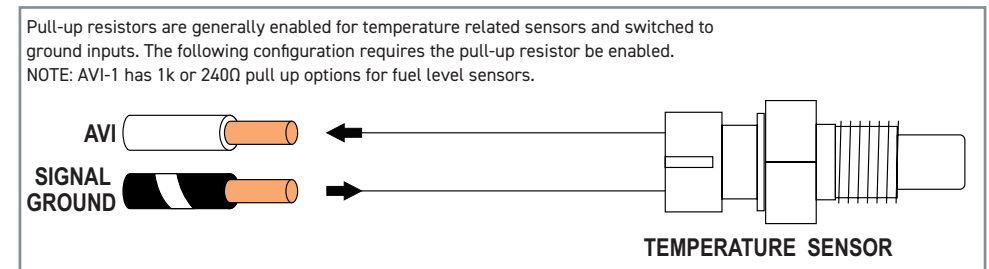

CAN Bus

The Nexus PD16 includes a single CAN bus. The CAN Bus MUST be connected to a Haltech Elite ECU or Nexus VCU for the PD16 to operate.

Specs

- 1000 kbit/s
- Selectable 120R termination
- -40 to 40V short protection
- Supports Haltech Elite and Nexus ECUs

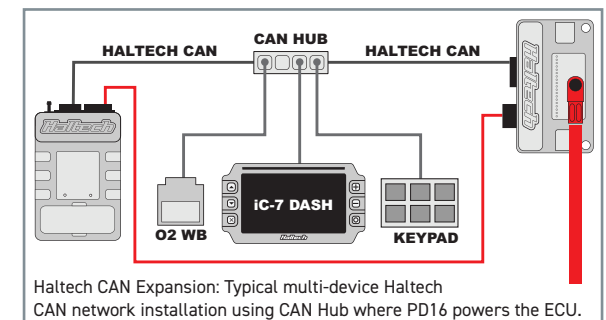

Pin	Colour	Connection
1	BR/Y	Half Bridge 1
2	BR/L	Half Bridge 2
3	P/R	8A High Current Output 1
4	P/BR	8A High Current Output 2
5	P/B	8A High Current Output 3
6	P/O	8A High Current Output 4
7	P/Y	8A High Current Output 5
8	P/G	8A High Current Output 6
9	P/V	8A High Current Output 7
10	P/L	8A High Current Output 8
11	B/W	Sensor Ground
12	O	5V Sensor Supply
13	P	Ignition Switch
14	GY/BR	SPI 1
15	GY/R	SPI 2
16	GY/O	SPI 3
17	P/GY	8A High Current Output 9
18	P/W	8A High Current Output 10
19	GY/Y	SPI 4
20	W	AVI 1
21	W/Y	AVI 2
22	B	CAN Ground
23	W	CAN H 1
24	L	CAN L 1
25	P	CAN 12V Out OR Wake on CAN power (CAN Ignition switch)
26	R	Low Current 12V constant for ignition switch input
27	W/GY	AVI 3
28	W/V	AVI 4
29		No Connection
30		No Connection
31	B	Battery Ground
32	B	Battery Ground
33	B	Battery Ground
34	B	Battery Ground

1	R/L	25A High Current Output 1
2	R/Y	25A High Current Output 2
3	R/O	25A High Current Output 3
4	R/G	25A High Current Output 4

34 Pin Superseal Connector

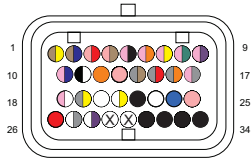

Looking into the PD16

4 Pin DTP4 Connector

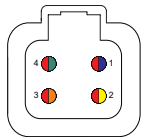

Looking into the PD16



WARRANTY CERTIFICATE

At Haltech we make every effort to design and manufacture fault-free products that perform up to or above the market expectations. All our products are covered by a Limited 12 Month Warranty.

Haltech Limited Warranty

Unless specified otherwise, Haltech warrants its products to be free from defects in material or workmanship for a period of 12 months from the date of purchase.

If the Haltech product is found to be defective as mentioned above, it will be replaced or repaired if returned prepaid along with proof of purchase. Proof of purchase in the form of a copy of the original purchase invoice, receipt or bill of sale which indicates that the product is within the warranty period, must be presented to obtain warranty service.

Replacement or repair of a defective product shall constitute the sole liability of Haltech. To the extent permitted by law, the foregoing is exclusive and in lieu of all other warranties or representations, either expressed or implied, including any implied warranty of merchantability or fitness. In no event shall Haltech, be liable for special or consequential damages.

Product Returns

Please include a copy of the original purchase invoice, receipt or bill of sale along with the unused, undamaged product and its original packaging. Any product returned with missing accessory items or packaging will incur extra charges to return the item to a re-saleable condition.

All product returns must be sent via a freight method with adequate tracking, insurance and proof of delivery services. Haltech will not be held responsible for product returns lost during transit.

Returns of Products Supplied in Sealed Packaging

The sale of any sensor or accessory supplied in sealed packaging is strictly non-refundable if the sealed packaging has been opened or tampered with. This will be clearly noted on the product packaging. If you do not accept these terms please return the sensor in its original unopened packaging within 30 days for a full refund.

A sensor or accessory product may be returned after 30 days of purchase (with its sealed packaging in tact) for credit only (no refunds given) and will be subject to a 10% restocking fee.

Installation of Haltech Products

No responsibility whatsoever is accepted by Haltech for the fitment of Haltech Products. The onus is clearly on the installer to ensure that both their knowledge and the parts selected are correct for that particular application. Any damage to parts or consequential damage or costs resulting from the incorrect installation of Haltech products are totally the responsibility of the installer.

Always disconnect the battery when doing electrical work on your vehicle. Avoid sparks, open flames or use of electrical devices near flammable substances. Do not run the engine with a battery charger connected as this could damage the ECU and other electrical equipment.

Do not overcharge the battery or reverse the polarity of the battery or any charging unit. Disconnect the Haltech ECU from the electrical system whenever doing any welding on the vehicle by unplugging the wiring harness connector from the ECU.

After completing the ECU installation, make sure there is no wiring left un-insulated. Uninsulated wiring can cause sparks, short circuits and in some cases fire. Before attempting to run the engine ensure there are no leaks in the fuel system.

All fuel system components and wiring should be mounted away from heat sources, shielded if necessary and well ventilated. Always ensure that you follow workshop safety procedures. If you're working underneath a jacked-up car, always use safety stands!

Haltech Off-Road Usage Policy

In many states it is unlawful to tamper with your vehicle's emissions equipment. Haltech products are designed and sold for sanctioned off-road/competition non-emissions controlled vehicles only and may never be used on a public road or highway.

Using Haltech products for street/road use on public roads or highways is prohibited by law unless a specific regulatory exemption exists (more information can be found on the SEMA Action Network website www.semasan.com/emissions for state by state details in the USA).

It is the responsibility of the installer and/or user of this product to ensure compliance with all applicable local and federal laws and regulations. Please check with your local vehicle authority before purchasing, using or installing any Haltech product.



Haltech Australia

17 Durian Place,
Wetherill Park NSW 2164
Australia
Phone: +61 2 9729 0999
Email: aus@haltech.com

Haltech USA East

750 Miles Point Way,
Lexington, KY 40510 USA
Phone: +1 888 298 8116
Email: usa@haltech.com

Haltech UK

Unit 1, Miras Business Estate,
Keys Park Road, Hednesford,
WS12 2FS
Phone: +44 121 285 6650
Email: uk@haltech.com

Haltech New Zealand

9B Weza Lane, Kumeu 0810
Phone: 09 887 0616
Email: nz@haltech.com

Haltech USA West

26429 Rancho Parkway S, Unit 125
Lake Forest, CA 92630 USA
Phone: +1 949 490 5660
Email: usa@haltech.com

Haltech Europe

Ottogasse 2A,
2333 Leopoldsdorf, Austria
Phone: +43 720 883968
Email: europe@haltech.com



facebook.com/HaltechEngineManagement



youtube.com/haltechecu



instagram.com/haltechecu